



AIR CONDITIONING



REFRIGERATION



HEATING



# heavy duty 6 & 10

## CONDENSATE REMOVAL PUMP

With an impressive flow rate, these robust and reliable Heavy Duty pumps are perfect for the rapid removal of large quantities of condensate water.

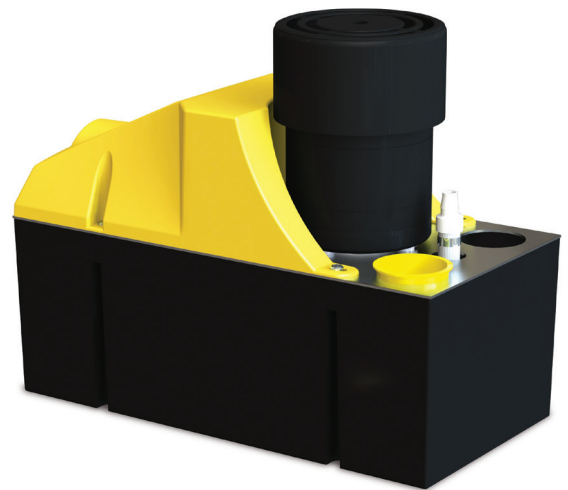

HD6: 900L/h max. flow  
HD10: 1070L/h max. flow



HD6: 7m max. rec. head  
(flow rate 180L/h)  
HD10: 9m max. rec. head  
(flow rate 100L/h)

### KEY FEATURES

- High flow rate
- Non return valve
- Easy installation
- 4 litre tank capacity

### SUITABILITY

- HD6: Up to 1200kW / 4m Btu/h  
HD10: Up to 1460kW / 4.9m Btu/h
- Refrigeration cabinets; Humidifiers;  
Air handling units (AHUs)

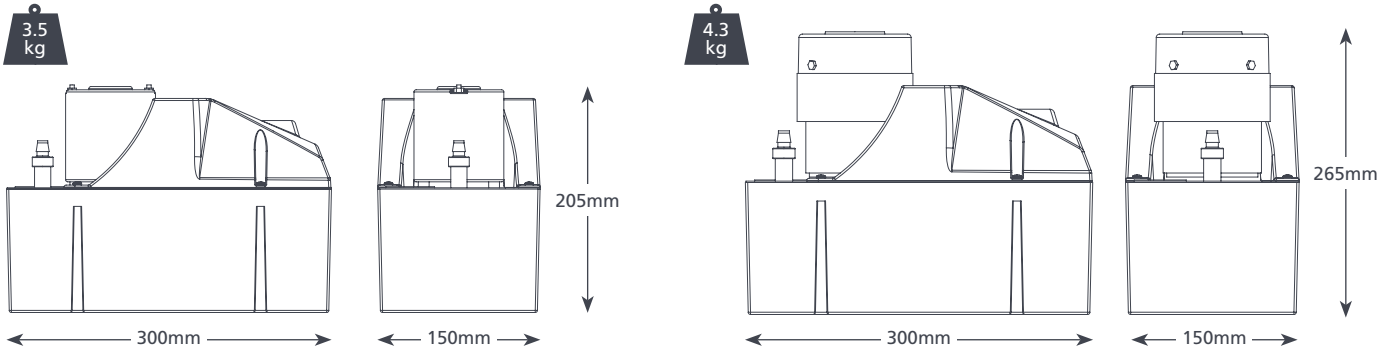

### HEAVY DUTY 6 & 10 SPECIFICATIONS

Max. flow	HD6: 900L/h, HD10: 1070L/h
Max. rec. head	HD6: 7m, HD10: 9m
Tank capacity	4L
Sound level@1m	HD6: 60dB(A), HD10: 64dB(A)
Power supply	HD6: 230V AC 50-60Hz 1.5A HD10: 230V AC 50-60Hz 0.38A
Rated	HD6: Non continuous HD10: Continuous
Class	I appliance
Max. unit output	HD6: 1200kW / 4m Btu/h HD10: 1460kW / 4.9m Btu/h
Max. water temp	40°C / 104°F
Inlet/outlet	x2 40mm in, 10mm out
IP Protection	IPX0
Safety switch	4.0A Normally closed

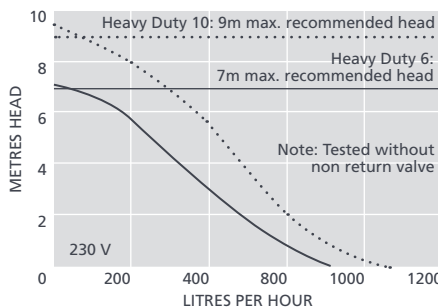

### SUGGESTED XTRA ACCESSORIES

Description	Part No.
Tank pump connector 16mm-21mm	FP2011
Tube To Soil Stack Adaptor	FP2038
Vinyl Tube Braided 1/4" (6mm)	AX5110
StayClean Tablets	FP2418

*Xtra* For more installation accessories take a look at our Aspen Xtra range

### HEAVY DUTY 6 & 10 OPTIONS

Heavy Duty 6	FP2074/2
Heavy Duty 10	FP2066/2

### IN THE BOX

Heavy Duty 6 or 10 pump • 2m power cable  
• Install manual

Download manual at [aspenspumps.com](http://aspenspumps.com)

Information correct at time of going to press.