

PROJECT REF:	STAND RANGE
UNIT REF:	N/A
FOOT PRESSURE:	N/A
UDL:	N/A

Material grade: BS EN 10219-1:2006 (S235JR). Welding standard: BS EN ISO 15614-1. Galvanizing standard: BS EN ISO 1461:2009
 Reference specification document "Custom Fabrication Specification" (BF-SPEC-050411) for further information
 Reference specification document "Big Foot Systems Cross Bar Specification (BF-SPEC-230610) for further information

		Mini Split Stand Range							VRF/VRV Stand Range					
Part Number		B5550	B5551	B5552	B5553	B5554	B5555	B5556	B5556	B5557	B5558	B5559	B5560	B5561
Description		Mini Split Low	Mini Split High	Mini Split Tower	MS Low Extension	MS High Extension	MS Riser Kit 4 Pack	MS Riser Kit 2 Pack	VRF/VRV 990	VRF/VRV 1290	VRF/VRV 1450	VRF/VRV 990 Extension	1290 Extension	1450 Extension
Number of Feet		4	4	4	2	2	-	-	4	4	4	2	2	2
A	Overall Length	mm 700	700	700	1060	1060	n/a	n/a	1230	1530	1690	1030	1330	1490
		inches 27 9/16	27 9/16	27 9/16	41 3/4	41 3/4	n/a	n/a	48 1/2	60 1/4	66 1/2	40 1/2	52 3/8	58 5/8
B	Overall Width	mm 1125	1125	1125	1125	1125	n/a	n/a	1360	1360	1360	1360	1360	1360
		inches 44 1/4	44 1/4	44 1/4	44 1/4	44 1/4	n/a	n/a	53 1/2	53 1/2	53 1/2	53 1/2	53 1/2	53 1/2
C	Distance Between Feet	mm 300	300	300	775	775	n/a	n/a	830	1130	1290	830	1130	1290
		inches 11 13/16	11 13/16	11 13/16	30 1/2	30 1/2	n/a	n/a	32 5/8	44 1/2	50 3/4	32 5/8	44 1/2	50 3/4
Height	mm	305	450	305/1000	305	450	152	152	305	305	305	305	305	305
	inches	12	17 11/16	12/39 3/8	12	17 11/16	6	6	12	12	12	12	12	12
Frame Weight	kg	20	22	35	18	19	1.5	0.75	35	38	41	25	28	31
	lbs	44	49	77	40	42	3	2	77	84	90	55	62	68
Design Load	kg	175	175	300	175	175	-	-	600	500	400	600	500	400
	lbs	385	385	661	385	385	-	-	1323	1102	882	1323	1102	882

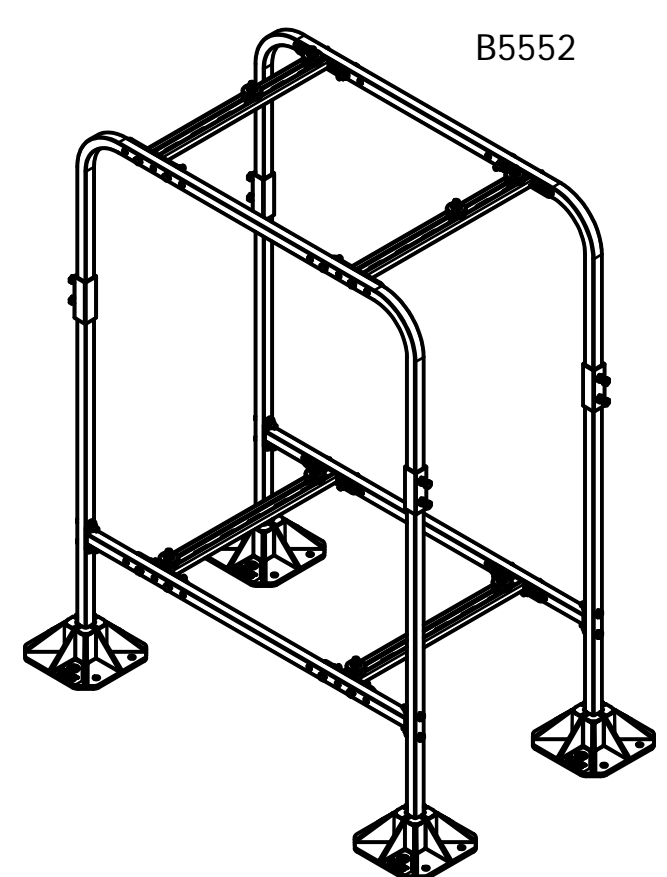
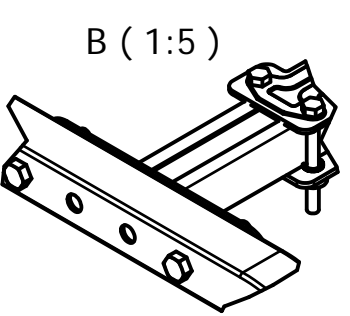
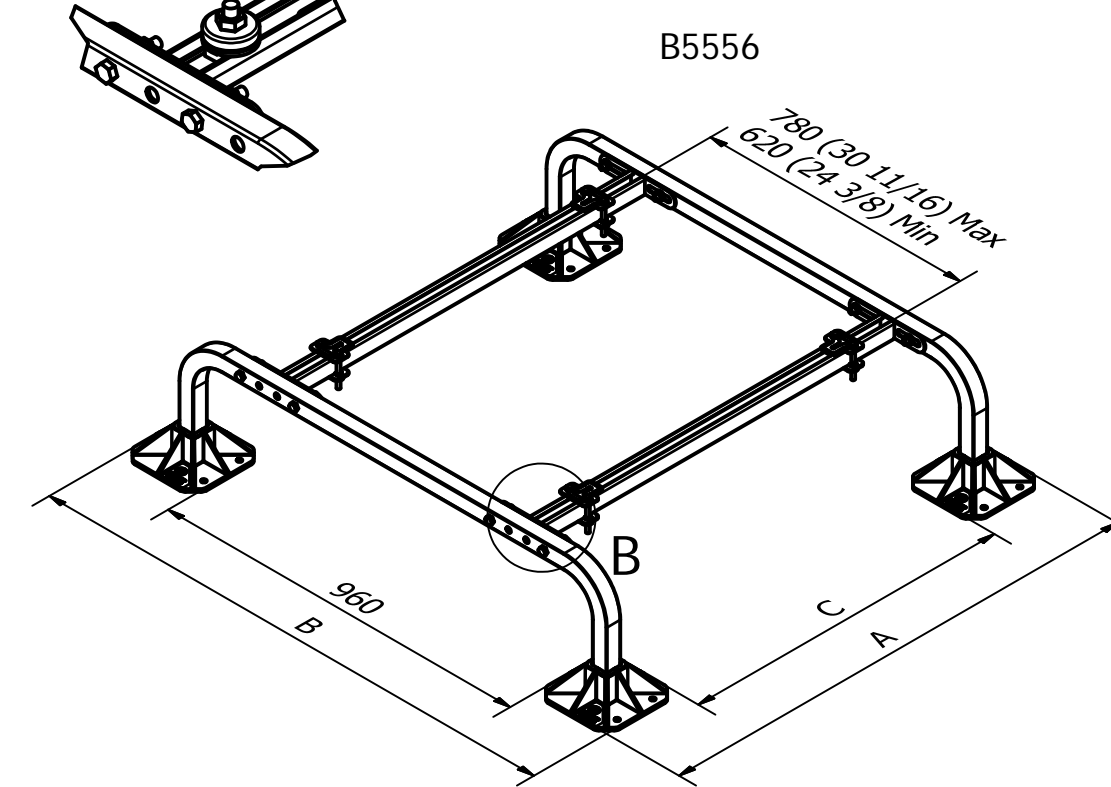
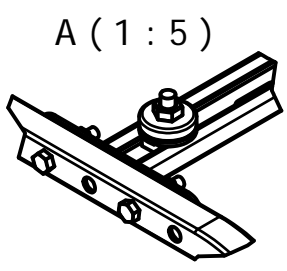
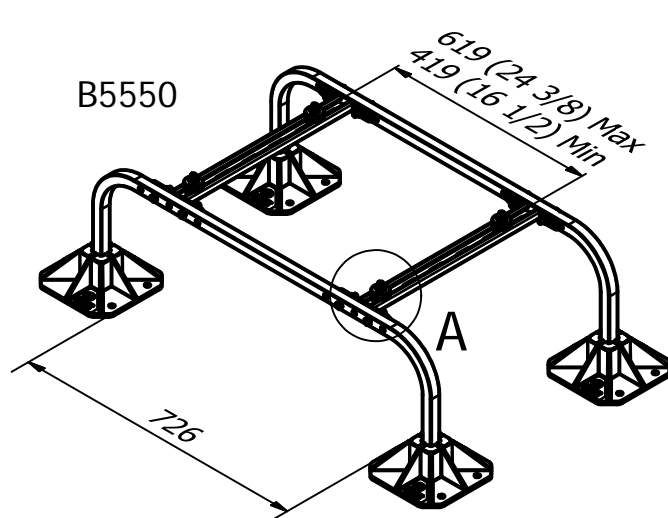

Design load based on maximum allowable deflection on cross members. Allowable foot pressure will be subject to roof build-up, typically detailed by a structural engineer. Cross bar spacings are adjustable to accommodate various unit sizes.

Working conditions: Suitable for internal or external applications in temperatures between -40°C to +80°C

Material Specification				
Part/Description	Material	Regulation Conformance	Density	
			kg/m3	lbs/ft3
Foot	Nylon GF-30%		1140	71
Metalwork	Galvanised Steel ASTM-A36	BS EN ISO1461:1999	7800	487

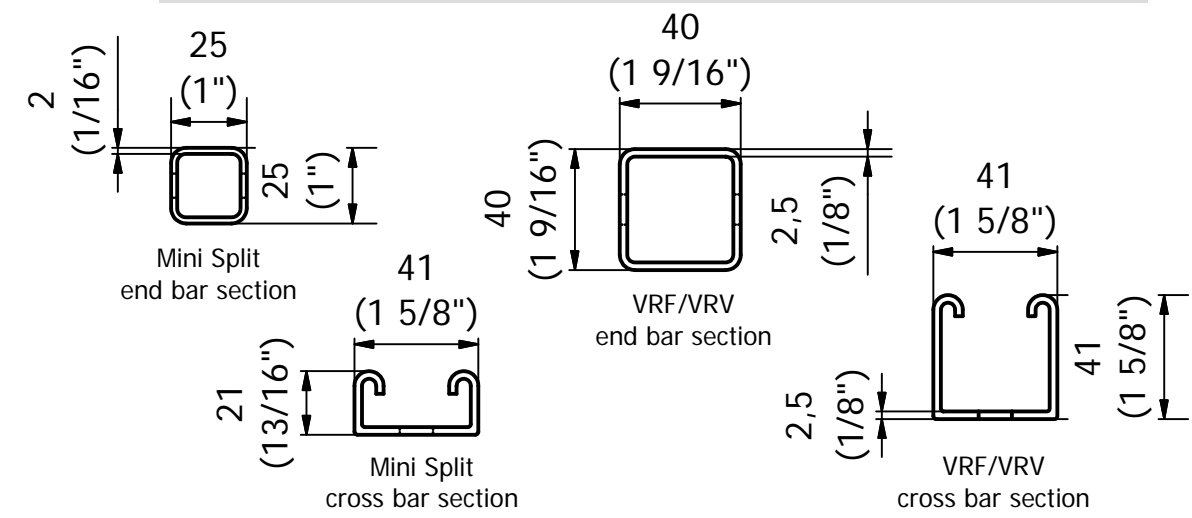

Installation and application considerations should include health, safety and environmental needs, regulations and standards, codes of practice, climate conditions, installation location, product orientation, evaluation of the roof structure, composition, surface and condition, ancillary and complimentary products and materials. Big Foot Systems recommend that all rooftop products are handled and installed by suitably qualified persons. All scheme designs are based on the use of Big Foot Systems' products and materials only. Terms and conditions available on request

REV A	DATE:	07/12/2015	SCALE: 1 : 15	A3
	DRAWN:	S BIRCH		
	CHECKED:	A SIMMANS		
			DIMENSIONS IN mm U.O.S	
			TOLERANCES: 0.0 ± 0.5mm U.O.S	
			SHEET 1 OF 2	

TITLE:	Stand Range Technical Data Sheet
DWG No.	BFT-SR.dwg
THIS DRAWING IS COPYRIGHT AND THE PROPERTY OF BIG FOOT SYSTEMS LIMITED	



PROJECT REF:	STAND RANGE
UNIT REF:	N/A
FOOT PRESSURE:	N/A
UDL:	N/A

Material grade: BS EN 10219-1:2006 (S235JR). Welding standard: BS EN ISO 15614-1. Galvanizing standard: BS EN ISO 1461:2009
Reference specification document "Custom Fabrication Specification" (BF-SPEC-050411) for further information
Reference specification document "Big Foot Systems Cross Bar Specification (BF-SPEC-230610) for further information

Stand Range Loading Data

Stand	Unit details											Foot Pressure		UDL		
	Type	Weight		No. of Feet	Length		Width		Height		Weight		kN/m2	psf	kN/m2	psf
		kg	lbs		mm	inches	mm	inches	mm	inches	kg	lbs				
MS Low	20	44	4	765	30 1/8	285	11 1/4	550	21 5/8	38	84	3.56	74.27	0.72	15.09	
MS Low	20	44	4	900	35 7/16	320	12 5/8	770	30 5/16	72	159	5.64	117.81	1.15	23.94	
MS Low	20	44	4	940	37	320	12 5/8	1430	56 5/16	101	223	7.42	154.95	1.51	31.48	
MS High	22	49	4	900	35 7/16	320	12 5/8	770	30 5/16	72	159	5.76	120.37	1.17	24.46	
MS Tower (2no. units)	35	77	4	900	35 7/16	320	12 5/8	770	30 5/16	72	159	6.56	137.02	1.33	27.84	
MS Low + Ext (2no. units)	38	84	6	765	30 1/8	285	11 1/4	550	21 5/8	38	84	4.66	97.32	0.40	8.26	
MS Low + Ext (2no. units)	38	84	6	900	35 7/16	320	12 5/8	770	30 5/16	72	159	7.44	155.37	0.57	11.96	
VRV/VRV 990	35	77	4	930	36 5/8	765	30 1/8	1680	66 1/8	191	421	13.86	289.40	1.33	27.68	
VRV/VRV 990	35	77	4	930	36 5/8	765	30 1/8	1680	66 1/8	254	560	17.72	370.08	1.69	35.40	
VRV/VRV 990 + Ext (2no. Units)	60	132	6	930	36 5/8	765	30 1/8	1680	66 1/8	254	560	23.22	484.90	0.90	18.70	
VRV/VRV 1290	38	84	4	1240	48 13/16	765	30 1/8	1680	66 1/8	281	619	19.56	408.49	1.50	31.41	
VRV/VRV 1290	38	84	4	1240	48 13/16	765	30 1/8	1680	66 1/8	334	736	22.81	476.36	1.75	36.63	
VRV/VRV 1290 + Ext (2no. Units)	66	146	6	1240	48 13/16	765	30 1/8	1680	66 1/8	334	736	30.00	626.61	1.01	21.07	
VRV/VRV 1450	41	90	4	1300	51 3/16	765	30 1/8	1680	66 1/8	339	747	23.30	486.60	1.62	33.87	
VRV/VRV 1450 + Ext (2no. Units)	72	159	6	1300	51 3/16	765	30 1/8	1680	66 1/8	339	747	30.66	640.27	0.93	19.47	

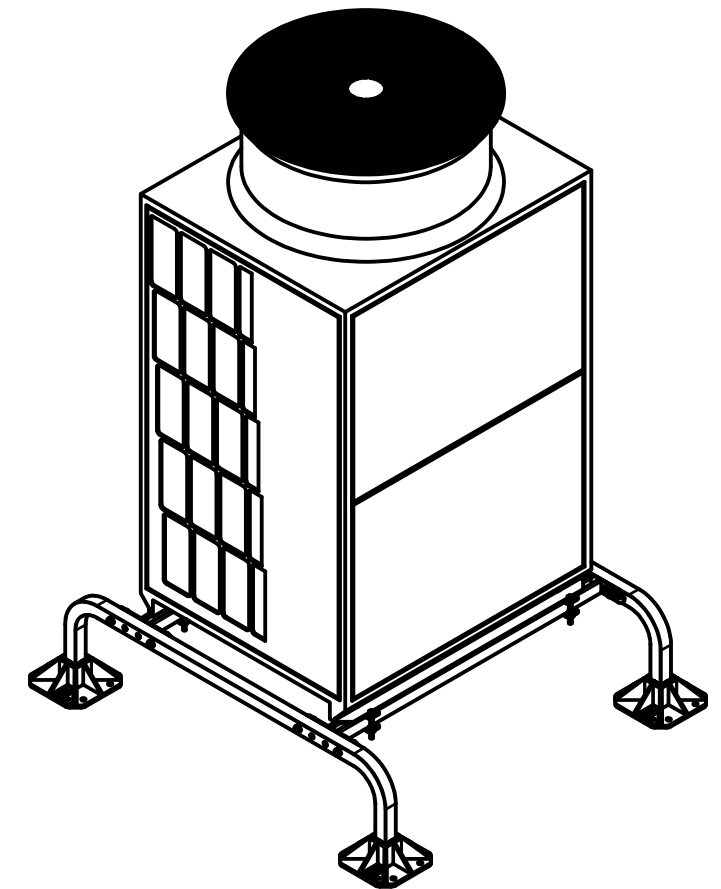
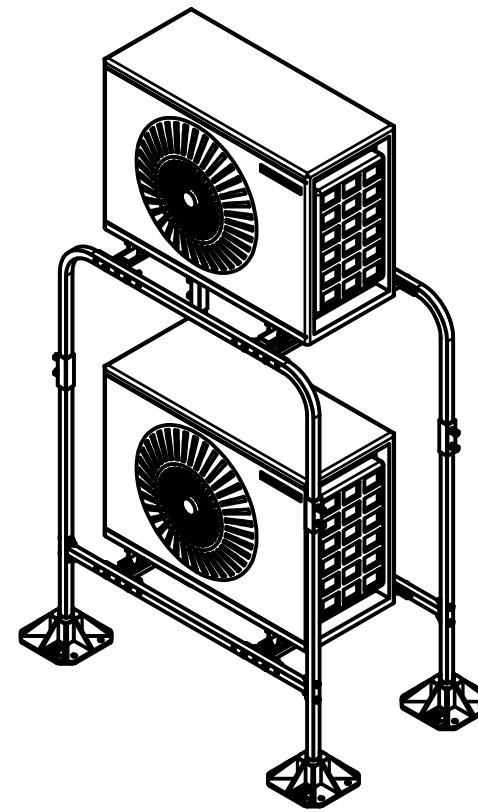
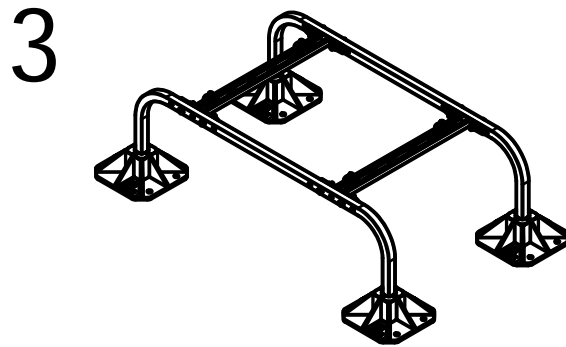
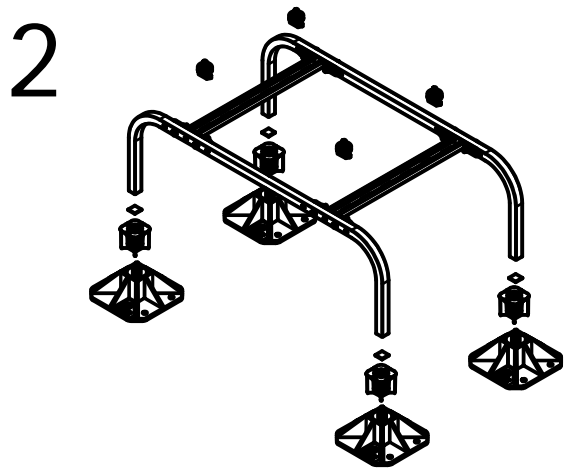
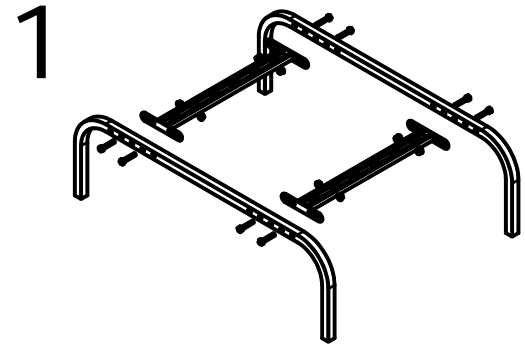

13 (x2) & 17mm
30Nm on frame bolts
10Nm on unit mounting bolts

Installation and application considerations should include health, safety and environmental needs, regulations and standards, codes of practice, climate conditions, installation location, product orientation, evaluation of the roof structure, composition, surface and condition, ancillary and complimentary products and materials. Big Foot Systems recommend that all rooftop products are handled and installed by suitably qualified persons. All scheme designs are based on the use of Big Foot Systems' products and materials only. Terms and conditions available on request

REV A	DATE:	07/12/2015
	DRAWN:	S BIRCH
	CHECKED:	A SIMMANS

SCALE: 1 : 15
DIMENSIONS IN mm U.O.S
TOLERANCES: 0.0 ± 0.5mm U.O.S
SHEET 2 OF 2

A3

TITLE:
Stand Range Technical Data Sheet
DWG No.
BFT-SR.dwg

THIS DRAWING IS COPYRIGHT AND
THE PROPERTY OF BIG FOOT SYSTEMS LIMITED

