

mini FLOWATCH® 2

SICCOM

Mini solenoid pump reliable and silent for the condensate removal of air conditioners up to 10kW / 36000BTU.

Ref: DE05LC4400

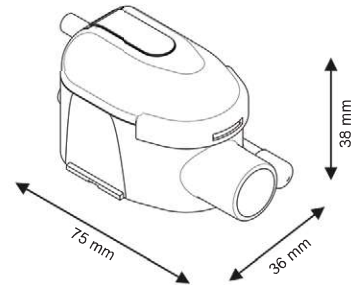
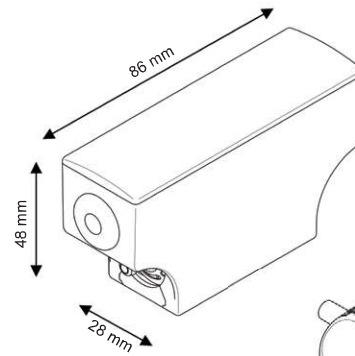

Hose diameter
Suction : 4/6 mm - supplied
Discharge : 6/9 mm - not supplied

SPECIFICATIONS

Flowrate max	15 l/h
Suction head max	2 m
Discharge head	10 m
Electrical power	19W
Voltage	220-240V 50/60Hz
Alarm	NO-NC
Noise level*	
Protection rating	IP64
Thermal protection	Yes
Operating cycle**	100%
Power / alarm cable	1.6 m
Dimensions	86 x 28 x 48 mm / 75 x 38 x 36 mm

* Notation from 1 wave (≤ 20 dBA) to 6 waves (> 45 dBA)

** The pump is able to run 100% of the time if necessary.

FLOWRATE

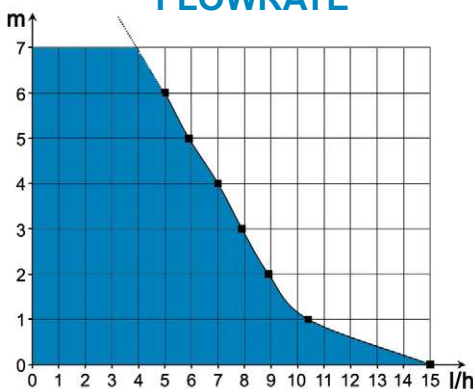

Recommended accessory



Kit COMFORT

Thanks to its patented foam casing, this kit reduces the noise level and makes the pump easier to install.

Ref: GC077G1027

BENEFITS



Very silent

Very silent pump (20.2 dBA), suitable for an installation in any room.



IP64 protection

Protected against water splashes and dust.



Quick connectors

Make installation and maintenance easier.



Clear reservoir

Facilitates maintenance thanks to a quick visualization of the reservoir state.



Brass outlet

More solid and reliable than plastic outlet.



Accessories included

All accessories required for installation are included in the box.

CONTENTS



Pump - Reservoir with air-vent tube - Power / alarm cable - Reservoir stand - Double-side adhesive - Inlet tube - Suction tube 1.8m - 1 clamp