

Installation & Maintenance Manual for Wired Controller Kit WK-B

This wired controller kit WK-B is required when wall mount type of indoor* needs to install with wired remote controller YR-E17 or YR-E16B or YR-E16A.

1.Installation parts

Installation diagram review

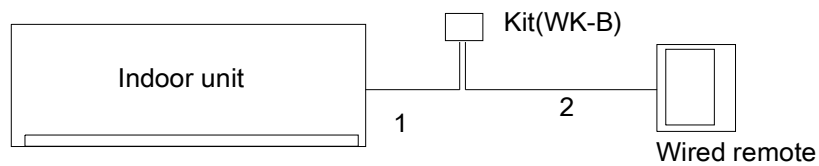

Step 1: This package includes the following accessories, 1) Base 2) front cover 3) PCB Board 4) wire cable 3.3 ft

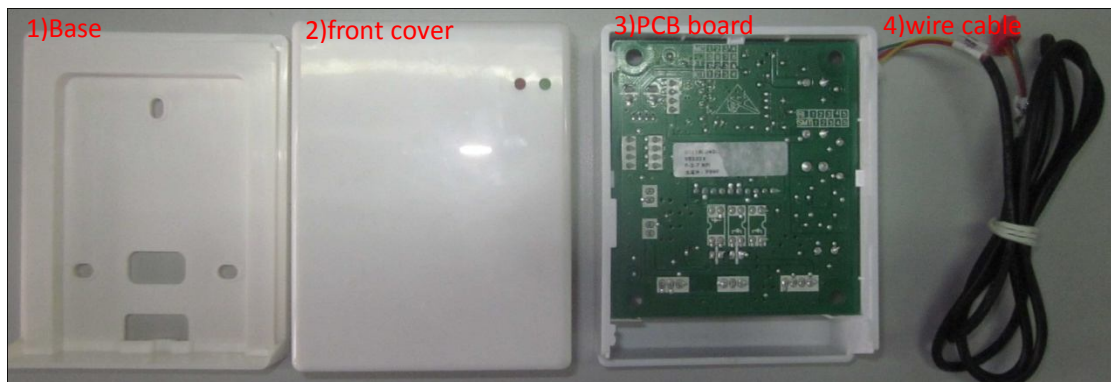

Picture 1.1

Step 2: Choose a proper location to install, eg. above the top or by the side of the unit



Picture 1.2

Step3 Please slide the box front cover up and cross the wire cable from the bottom hole as shown in picture 1.3. Fix the base with 3 screws on the wall.

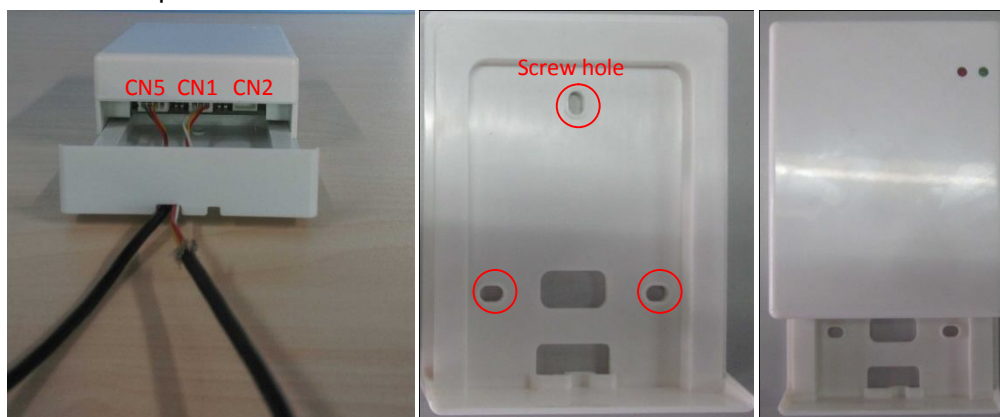

Picture 1.3

Step 4: Connect the terminals between the wall mount unit and WK-B.

Please use the cable in this box to connect terminal CN2 of the wall mount unit PCB board and terminal CN5 of WK-B. Pls note using right side of the cable to connect the terminal as the label instruction on the wire cable, e.g. white side of the cable is plugged into the terminal CN5 of WK-B.

Step 5: Connect the terminals between wired remote and WK-B.

Please connect the right terminal of wired remote and terminal CN1 on WK-B. The terminal CN1 of WK-B for master unit(unit 0) must connect the wired remote. The picture 1.4 is for reference of attaching.

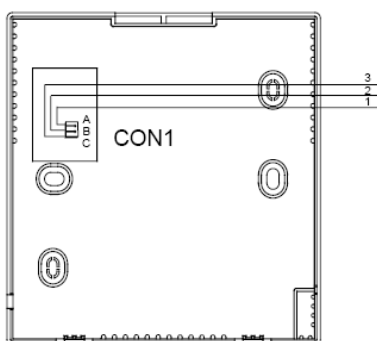

Picture 1.4

Step 6: Please slide the down cover up to complete the installation

2.Maintenance Parts

Now the kit is only available for wired remote controller YR-E16B and YR-E17 and YR-E16A

2.1 Wire Diagram for Single Zone

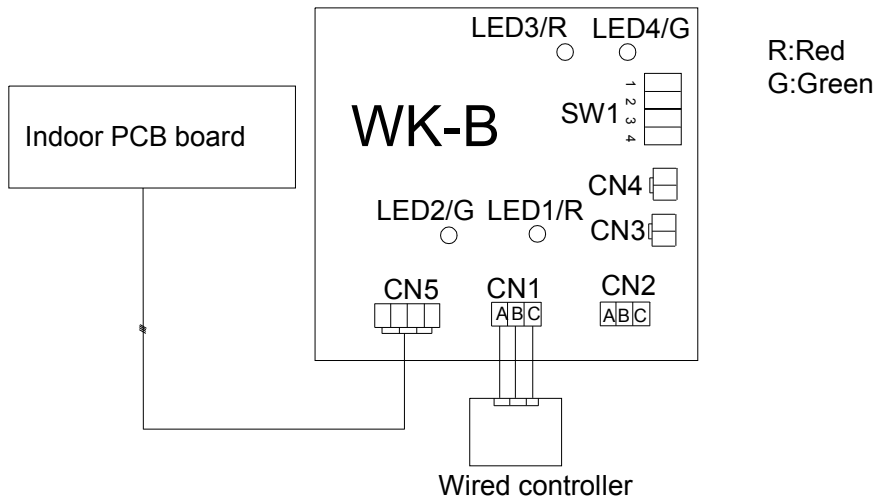

Picture 2.1

Remark:

- (1) SW1 Default DIP switch: OFF/OFF/OFF/OFF
- (2) There is a jumper for both terminal CN3 and CN4.

2.2 Wire Diagram for Multi Zone(Master and Slave

Upto 16 indoor unites can be connected by the wired remote at the same time, but each one requests 1 PC kit WK-B.

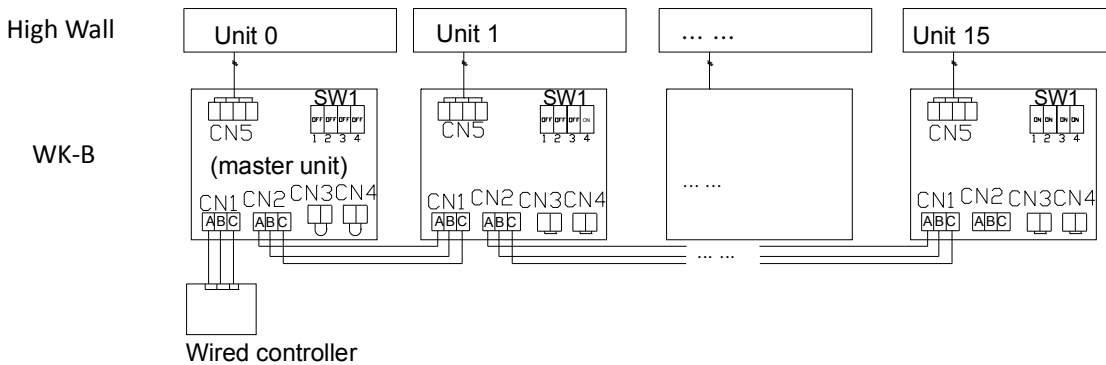

Picture 2.2

Remark:

- (1) The first high wall indoor unit to connect with WK-B is considered as master unit 0.
- (2) There is a jumper between terminal CN3 and CN4 for the master unit, while cut off the terminal for the slave unit.
- (3) The terminal CN1 of WK-B for master unit(unit 0) must connect the wired remote.

(4)The terminal CN2 of WK-B for master unit(unit 0) must connect the CN1 of WK-B for slave unit(unit 1), while there is no limited between the terminal CN2 and CN1 of WK-B for the next, e.g the CN2 of WK-B for slave unit 2 can connect the terminal CN2 or CN1 of WK-B for slave unit 3.

(5)pls see the attached list for Master/slave DIP switch setting of WK-B.

AC Indoor Address (SW1):

1 2 3 4

off off off off : 0 (Master default IP 0000)

off off off on : 1(Slave IP 0001)

..... : ...and so on

on on on on : 15(Slave IP 1111)

Unit No.	DIP Switch position (1234)	Unit No.	DIP Switch position (1234)
0	off off off off	8	on off off off
1	off off off on	9	on off off on
2	off off on off	10	on off on off
3	off off on on	11	on off on on
4	off on off off	12	on on off off
5	off on off on	13	on on off on
6	off on on off	14	on on on off
7	off on on on	15	on on on on

2.3.Indicator Light

The indicator light for single zone and multi zone is same.

2.3.1 LED1 (red) light, LED2 (green) light is the communication indicator.

If the wired remote and WK-B works are normal, the two lights keep flashing. After installation, the 2 lights will be hidden in the box.

2.3.2 LED3 (red) light is the failure indicator, which do not lighti in normal operation

flash 1 time: communication failure between indoor unit and WK-B.

flash 2 times: communication failure between wired remote and WK-B.

2.3.3 LED4 (green) light is the operation indicator. The unit works normally when LED4 is on.