

BlueDiamond®

condensate removal pumps

MicroBlue®

With no additional silencing accessories required, not only is the MicroBlue® a silent running pump but it can also be mounted in any orientation whilst operating both wet and dry continuously. The MicroBlue® is a dual voltage pump which uses proven thermistor level sensing technology to remove the risk of stuck or sunken float switches.

New GyRok™
Technology



Ducting Kit
(X85-507)

Performance

🔊 17dba

Max flow	Max head	Max suction lift
5 litres/hour	5 metres	2 metres

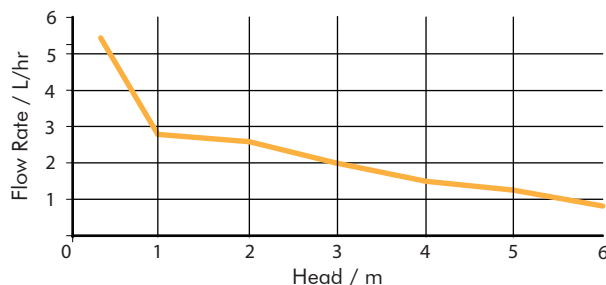

Sensing Options

MicroBlue® pump available with:

Reservoir sensor	Ducting Kit
X85-003 (HLA PACK)	X85-507 (HLA PACK)
	

Dimensions (mm)

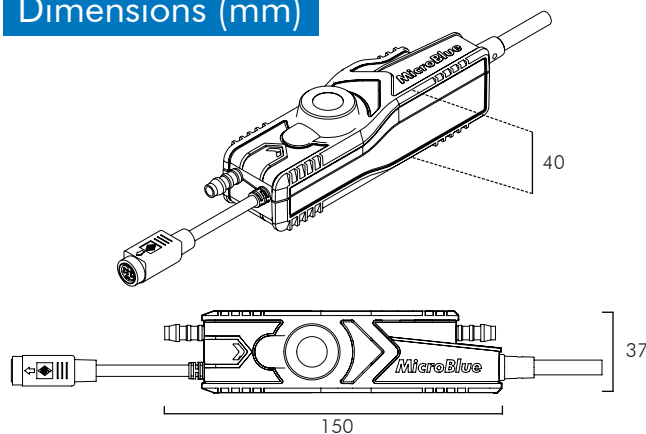

Installation Options

The MicroBlue® can be mounted in any orientation up to 2m away from the air conditioning unit.

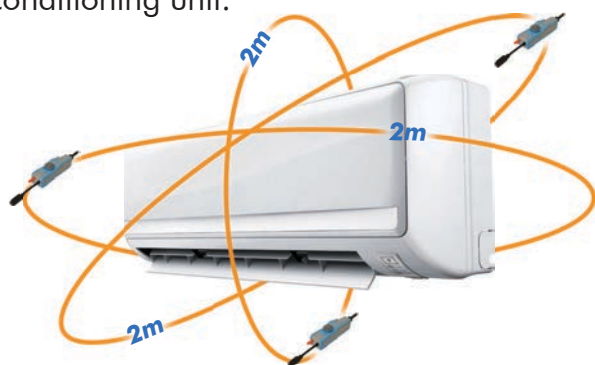

GyRok™
Technology



Indicator



DIN plug



3 year
warranty