















# Roof support

## Maximum spread load

### 140 kg

	VTE M8x40 UNI5739 4 PCS		LEVEL 1 PCS		VTE M8x20 UNI5739 2 PCS
	Ø 40 4 PCS		CAGE NUT M6 4 PCS		M8 2 PCS
	8x24 4 PCS		TBEI M6x16 UNI7380 4 PCS		BRACKET 4 PCS
	M8 UNI6592 4 PCS		M6x55 2 PCS		VTE M6x65 2 PCS
	M8 UNI5588 4 PCS		M6 UNI7473 4 PCS		
	Ø 25 4 PCS				

AV210

RG630

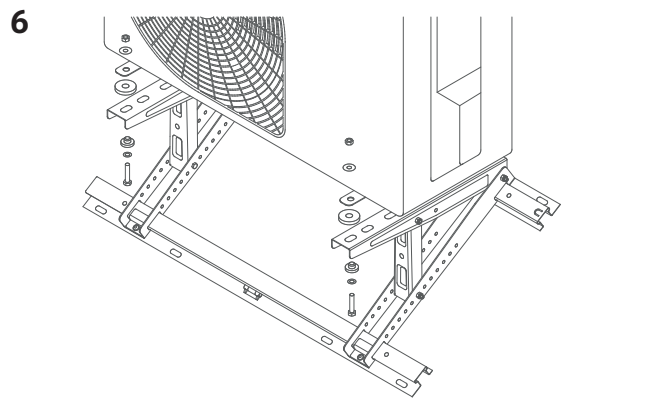
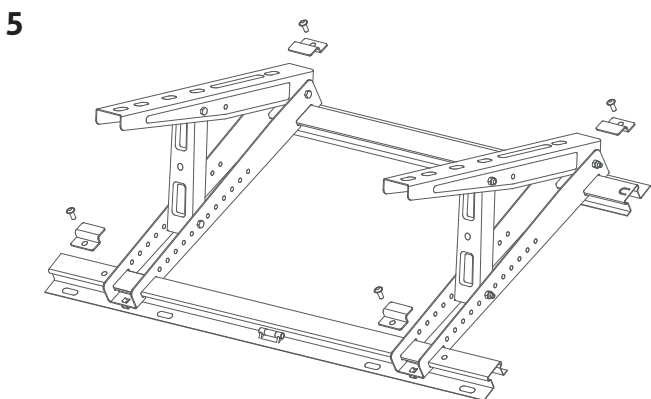
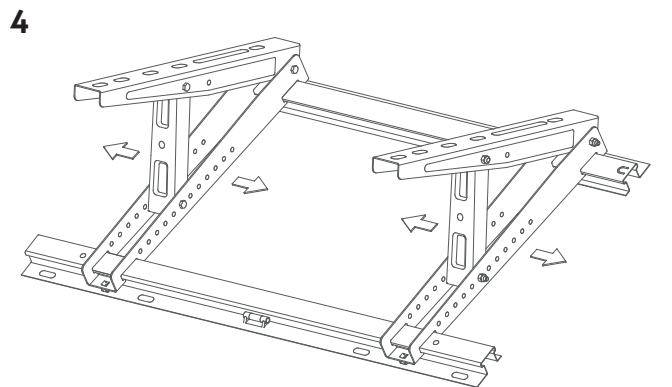
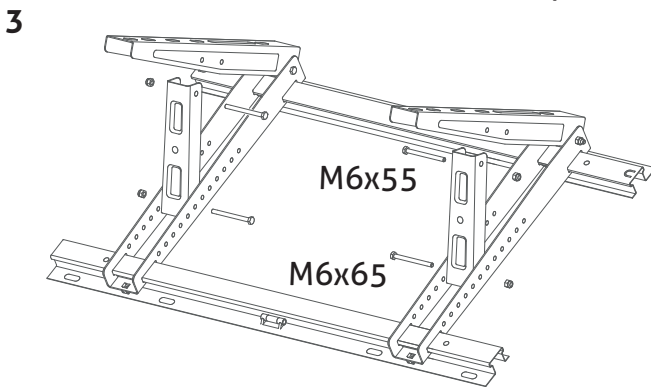
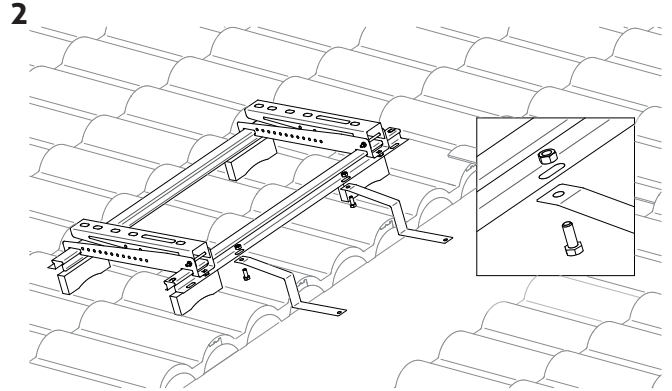
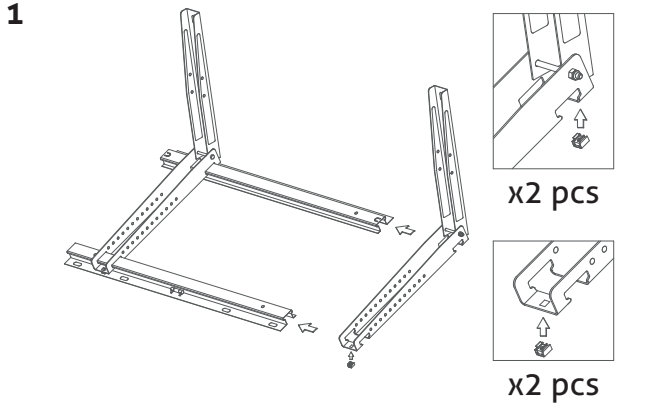

**Disclaimer:** this document cancels and replaces all former versions. We reserve us the right to amend it without prior notice. It is the sole and entire responsibility of the customer to obtain the most recent version in force of this document. It can be obtained by a simple written request to the Seller. The products mentioned in this document are exclusively for \*HVAC-R professionals customers (\*Heating Ventilation, Air Conditioning and Refrigeration). This product is a wall bracket designed for the support of an external condensing split air conditioner device. Nether Seller nor the Manufacturer shall be liable for any injury, loss or damages, either direct, incidental or consequential (including but not limited to, incidental or consequential damages for lost profits, lost sales, injury to person or property, or any other incidental or consequential loss) arising out of the use or the inability to use the product, and the customer agrees that no other remedy shall be available to it. The customer is required to control whether the products mentioned in this document are appropriate for their intended use.

As totally beyond the control of the Manufacturer and the Seller, it is the sole and entire responsibility of the customer to check and comply with all national, state, local and environmental regulations, safety factors according to intended application. It is also the customer's sole and entire responsibility to choose and use appropriate tools and materials according to the professional know-how, in conformity to the installation and maintenance instructions as well as recommendations in the manuals of the air conditioning device. It is as well the customer's sole and entire responsibility to evaluate if the supporting structure and elements, composition and surface, and if the supplied fixations are suitable for a safe and professional installation on the type of wall structure or surface that will be used to install the brackets and the air conditioning device on taking into account climatic conditions in use and during the installation. At least once per year the inspection of the tightening of the fixations as well as of the general condition of the bracket is required.

All claims or disputes are subject to the Manufacturer's and the Seller's General Conditions of Sales.